

EH Static Spray Ball Stainless Steel & Plastic Versions

EH

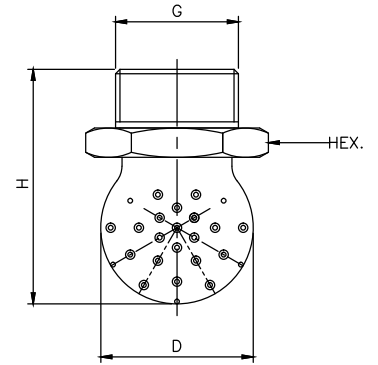
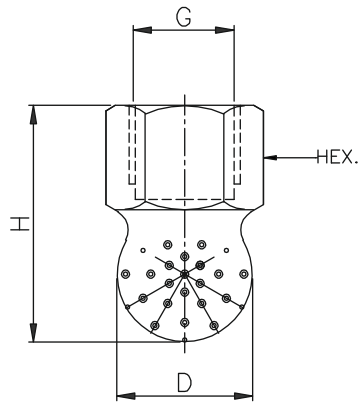

Female Connection

Male Connection

EH Series Static Spray Ball has very compact design that provides straight jets for high impact rinsing of small drums or container up to \varnothing 1.5m. Also it can be used with saturated steam. Spray coverage is available in 180° & 270°

SPRAY ANGLE

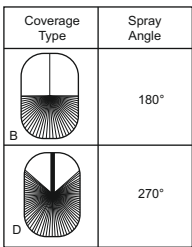

MODEL NO.	SPRAY ANGLE	CONNECTION			FLOW CAPACITY IN LPM AT DIFFERENT PRESSURE					
		1/4"	3/8"	1/2"	FLOW CAPACITY (US GPM)	PRESSURE [BAR]				
						40° psi	1.5	2	3	5
EH1.800	B/D	●			2.45	6.93	8.00	9.80	12.65	14.97
EH2.100	B/D	●			3.09	8.66	10.00	12.25	15.81	18.71
EH2.120	B/D	●			3.71	10.39	12.00	14.70	18.97	22.45
EH2.140	B/D	●			4.33	12.12	14.00	17.15	22.14	26.19
EH2.160	B/D	●			4.90	13.86	16.00	19.60	25.30	29.93
EH2.180	B/D	●	●	●	5.50	15.59	18.00	22.05	28.46	33.67
EH2.220	B/D		●	●	6.32	19.05	22.00	26.94	34.79	41.16
EH2.280	B/D		●	●	8.58	24.25	28.00	34.29	44.27	52.38
EH2.320	B/D		●	●	9.81	27.71	32.00	39.19	50.60	59.87
EH2.400	B/D		●	●	12.38	34.64	40.00	48.99	63.25	74.83
EH2.520	B/D		●	●	15.94	45.03	52.00	63.69	82.22	97.28
EH2.600	B/D			●	18.58	51.96	60.00	73.48	94.87	112.25
EH2.700	B/D			●	21.68	60.62	70.00	85.73	110.68	130.96
EH2.800	B/D			●	24.52	69.28	80.00	97.98	126.49	149.67
EH2.900	B/D			●	27.87	77.94	90.00	110.23	142.30	168.37
EH3.100	B/D			●	30.65	86.60	100.0	122.47	158.11	187.08

End Connection : X – BSP, Y - BSPT, Z – NPT Available.

CONNECTION	1/4"			3/8"			1/2"		
DIMENSION	H	H1	D	H	H1	D	H	H1	D
MALE	32	15	16	35	16.5	17	40	26	27
	Weight (Metals) = XX gms. Approx			Weight (Metals) = XX gms. Approx			Weight (Metals) = XX gms. Approx		
FEMALE	32	15	16	35	21.5	22	45.3	26	27
	Weight (Metals) = XX gms. Approx			Weight (Metals) = XX gms. Approx			Weight (Metals) = XX gms. Approx		