

CAEA Series Flat External Air Atomizing Spray Nozzles

DESIGN / SPRAY CHARACTERISTICS

- External mix: allows spraying of viscous materials
- Variable atomization
- Moderate spray angle (range 60°- 90°)
- Precise metering of the liquid flow rate

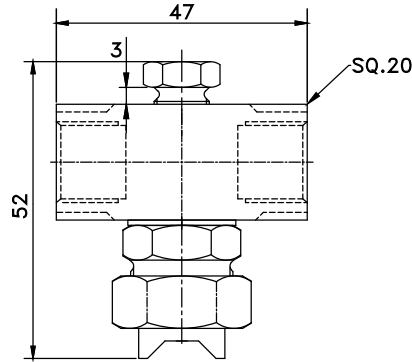
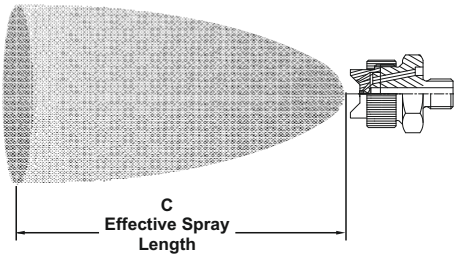

Flow Rates and Dimensions

Siphon-fed, External Mix, Flat Spray Pattern, 1/8" and 1/4" Pipe Sizes, BSP or NPT

Orifice size & water flow		Water Pressure [kg/cm ²]									
		Pressure 0.2 Bar	Pressure 0.4 Bar	Pressure 0.6 Bar	Pressure 0.8 Bar	Pressure 1 Bar	Pressure 1.2 Bar	Pressure 1.4 Bar	Pressure 1.6 Bar	Pressure 1.8 Bar	Pressure 2 Bar
0.5	ML/MIN	80	100	130	150	170	190	200	210	210	210
	LPH	4.8	6	7.8	9	10.2	11.4	12	12.6	12.6	12.6
0.6	ML/MIN	160	200	240	260	300	320	340	360	380	400
	LPH	9.6	12	14.4	15.6	18	19.2	20.4	21.6	22.8	24
0.7	ML/MIN	170	220	250	300	320	340	360	400	420	440
	LPH	10.2	13.2	15	18	19.2	20.4	21.6	24	25.2	26.4
0.8	ML/MIN	260	300	360	400	440	480	510	540	580	610
	LPH	15.6	18	21.6	24	26.4	28.8	30.6	32.4	34.8	36.6
0.9	ML/MIN	280	320	380	420	470	500	540	580	600	640
	LPH	16.8	19.2	22.8	25.2	28.2	30	32.4	34.8	36	38.4
1	ML/MIN	340	420	500	560	620	680	720	740	760	780
	LPH	20.4	25.2	30	33.6	37.2	40.8	43.2	44.4	45.6	46.8
1.1	ML/MIN										
	LPH										
1.2	ML/MIN	440	540	640	760	840	900	990	1040	1080	1100
	LPH	26.4	32.4	38.4	45.6	50.4	54	59.4	62.4	64.8	66
1.3	ML/MIN	740	760	880	1000	1100	1200	1300	1380	1200	1260
	LPH	44.4	45.6	52.8	60	66	72	78	82.8	72	75.6
1.4	ML/MIN	760	880	940	1100	1200	1300	1400	1500	1560	1600
	LPH	45.6	52.89	56.4	66	72	78	84	90	93.6	96
1.5	ML/MIN	800	1000	1200	1300	1440	1580	1660	1800	1900	1980
	LPH	48	60	72	78	86.4	94.8	99.6	108	114	118.8

Standard Materials: Nickel-plated Brass, 303 Stainless Steel and 316 Stainless Steel.

CAEA Series Flat External Air Atomizing Spray Nozzles



Pipe Size	Model No.	0.7 Bar Liquid			1.5 Bar Liquid			2.0 Bar Liquid			3.0 Bar Liquid			4.0 Bar Liquid			Spray Dimensions									
		Air (bar)	l/h	Nm ³ /h	Air (bar)	l/h	Nm ³ /h	Air (bar)	l/h	Nm ³ /h	Air (bar)	l/h	Nm ³ /h	Air (bar)	l/h	Nm ³ /h	"C" Effective Spray Length(mm)	Max. Spray Length (m)								
1/8 or 1/4	CAEA 350	0.6	13	5.46	16	6.12	25	9.36	37	12.6	52	17.1	68	25.8	18.6	22.6	510	3.5								
		0.7		6.12		7.80		1.1		1.4		1.8		2.1					2.5	2.8	3.2	3.5	4.2	4.6	5.2	5.8
		1.1		7.80		9.36		1.8		2.1		2.5		2.8					3.2	3.5	4.2	4.6	5.2	5.8	6.4	6.9
1/8 or 1/4	CAEA 400	0.7	13	5.10	16	6.12	25	6.96	37	8.34	52	10.7	68	12.7	18.6	22.6	250	1.7								
		1.0		6.12		7.80		1.4		1.8		2.1		2.5					2.8	3.2	3.5	4.2	4.6	5.2	5.8	
		1.4		6.96		8.34		1.8		2.1		2.5		2.8					3.2	3.5	4.2	4.6	5.2	5.8	6.4	6.9
1/8 or 1/4	CAEA 450	0.6	18	5.46	22	6.12	33	7.80	48	9.36	68	11.7	88	13.6	18.6	22.6	510	3.5								
		1.1		7.80		9.36		1.4		1.8		2.1		2.5					2.8	3.2	3.5	4.2	4.6	5.2	5.8	
		1.4		9.36		11.0		1.8		2.1		2.5		2.8					3.2	3.5	4.2	4.6	5.2	5.8	6.4	6.9
1/8 or 1/4	CAEA 500	0.7	18	5.10	22	6.96	33	8.34	48	10.7	68	12.7	88	15.3	18.6	22.6	270	2.1								
		1.0		6.12		7.80		1.4		1.8		2.1		2.5					2.8	3.2	3.5	4.2	4.6	5.2	5.8	
		1.4		6.96		8.34		1.8		2.1		2.5		2.8					3.2	3.5	4.2	4.6	5.2	5.8	6.4	6.9
1/8 or 1/4	CAEA 550	0.7	36	6.12	45	7.80	68	9.36	100	11.7	141	13.6	186	15.3	25.8	33.0	760	3.0								
		1.1		7.80		9.36		1.4		1.8		2.1		2.5					2.8	3.2	3.5	4.2	4.6	5.2	5.8	
		1.4		9.36		11.0		1.8		2.1		2.5		2.8					3.2	3.5	4.2	4.6	5.2	5.8	6.4	6.9
1/8 or 1/4	CAEA 600	1.0	36	6.12	45	8.34	68	10.7	100	12.7	141	14.8	186	16.5	25.8	33.0	760	3.0								
		1.4		6.96		8.34		1.8		2.1		2.5		2.8					3.2	3.5	4.2	4.6	5.2	5.8		
		1.8		8.34		10.7		2.1		2.5		2.8		3.2					3.5	4.2	4.6	5.2	5.8	6.4	6.9	7.3
1/8 or 1/4	CAEA 650	1.8	36	14.1	45	14.1	68	18.0	100	24.6	141	26.7	186	28.8	25.8	33.0	760	3.0								
		2.1		15.6		18.0		2.1		2.5		2.8		3.2					3.5	4.2	4.6	5.2	5.8			
		2.5		18.0		19.8		2.5		2.8		3.2		3.5					4.2	4.6	5.2	5.8	6.4	6.9	7.3	7.9
1/8 or 1/4	CAEA 700	2.1	64	15.6	78	19.8	119	24.6	175	31.2	175	33.9	186	36.0	25.8	33.0	760	3.5								
		2.5		18.0		19.8		2.1		2.5		2.8		3.2					3.5	4.2	4.6	5.2	5.8			
		2.8		19.8		21.3		2.5		2.8		3.2		3.5					4.2	4.6	5.2	5.8	6.4	6.9	7.3	7.9
1/8 or 1/4	CAEA 750	2.8	102	19.8	125	22.8	192	28.8	280	34.0	280	38.4	186	41.1	25.8	33.0	760	4.6								
		3.2		21.3		22.8		2.1		2.5		2.8		3.2					3.5	4.2	4.6	5.2	5.8			
		3.5		22.8		24.6		2.5		2.8		3.2		3.5					4.2	4.6	5.2	5.8	6.4	6.9	7.3	7.9

Standard Materials: Nickel-plated Brass, 303 Stainless Steel and 316 Stainless Steel.